



LIGHTWEIGHT ■ PORTABLE ■ SAFE



PORTA-DAVIT®

No. 1 in lightweight, portable, safe lifting solutions



PORTA-GANTRY®



PORTA-DAVIT®



T-DAVIT®



PORTA-QUAD®



PORTA-LIFTER®

Lightweight, 2 piece, bagged davit system with WLL to 500kg, yet only 24kg fully assembled



500Kg
WLL

1
person

25Kg
bagged

Lightweight, 2 piece, bagged davit system with WLL to 500kg, yet only 24kg fully assembled

With a safe lifting capacity to 500kg, yet made of lightweight aluminium weighing just 24kg fully assembled (standard product), the PORTA-DAVIT system is literally a one person "pick up and go" lifting solution. Manufactured using REID Lifting's innovative design, the PORTA-DAVIT bagged system can be easily transported by hand to any site that a single person can access.

Make lifting challenges safer and more cost effective with a REID PORTA-DAVIT:

- Less is more – 1 davit serves many locations
- Low maintenance costs – protective heavy duty bag, only exposed to environment when needed
- Centralised inspections and testing - reducing costs
- Safer to use – Manual handling compliant & clean to use – easily cleaned
- Better for environment – less materials, easily recycled, with high residual value and quality regional supply chain – lower carbon footprint
- All systems factory tested to 150% WLL prior to shipment



The Facts:

- Lightweight & portable - standard unit just 24kg assembled
- Strong yet light - High tensile Al alloy
- Simple assembly, 2 piece design, no tools needed
- WLL 500kg Goods and WLL 120kg Man-ride approved (EN795 Class B)
- Internal Bearing System - 360° rotation under finger tip control
- Radius adjustment (800-1200mm as standard) with shock load strap
- Corrosion resistant, high tensile aluminium alloy (powder coated finish) with low maintenance
- Manual handling compliance without mechanical aids - no tools required
- CE & EN795 Class B approved by Notified Body
- Goods & Manride approved
- Store and transport in heavy duty bag for easy handling and segregation
- Universal Kingpin – mates with wide range of REID sockets (or sleeves for existing sockets) as well as REID's new PORTA-BASE – the ultimately flexible system for use where no sockets are installed or possible

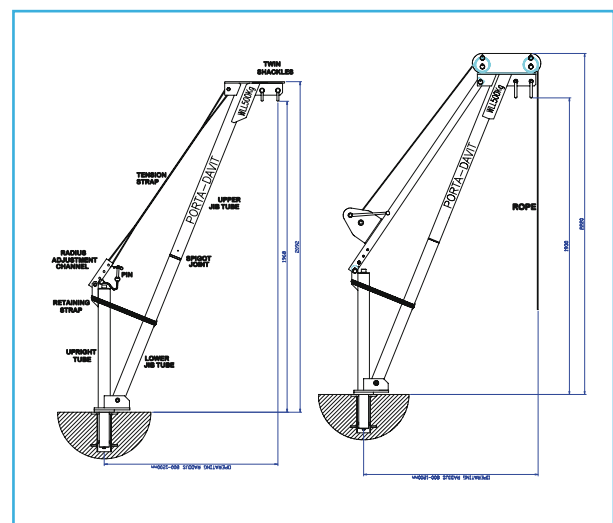

ASSEMBLY

ASSEMBLY WINCH OPTION

The PORTA-DAVIT is available in several variations to the base unit including standard winched versions, extended radius (e.g. WLL350, 1500mm radius), socket extensions, man-ride and PORTA-BASE & Counterbalanced versions.

Customised versions & bespoke specialised developments are always considered.

PORTA-DAVIT- man-rated options

The PORTA-DAVIT is available in three forms rated for man-ride:

- standard davit with a fall arrest unit fitted to a shackle (fall protection)
- with a man rated winch to lower and raise personnel and separate fall arrest unit with or without integral retrieval winch
- with a fall arrest with integral retrieval winch where the man moves on a ladder or climbing.

The PORTA-DAVIT system (using Reid mounting sockets) is approved to EN 795 Class B Anchor Devices, giving protection against falls from a height. The fall-arrest unit is compliant with EN 360.

We recommend that the PORTA-DAVIT unit has a dedicated man-ride rating only and is set at the minimum possible operating radius; however, it is possible to have the davit dual rated at 120kg for man ride and 500kg goods lifting. When used for man-ride applications the PORTA-DAVIT unit MUST be dedicated to the man-ride application only and there should be no goods load attached to the davit. Suitably rated Chain Block, winch and man-ride options and accessories are all available from REID Lifting:

PORTA-DAVIT – Customised & Bespoke:

Continuous development means REID has the capability to develop customised and bespoke davit solutions for those difficult and challenging lifting environments and applications, resulting in the REID T-Davit customised solutions as well as:

- Customised product developments
- Full “Design in” planning support
- Bespoke solutions development & consultancy
- Safe assembly, operation and maintenance training

PORTA-DAVIT variations:

- Standard winched versions
- Extended radius (e.g.WLL350, 1500mm radius)
- Manride EN 795 Class B Approved options

Wide range of options & accessories available:

- Chain hoists
- Winches – manual & electric
- Sockets
- Socket Extensions
- Extended radius option
- PORTA-BASE for ultimate flexible use



PORTA-DAVIT range			
	Winch	WLL (kg)	Radius range (mm)
PORTA-DAVIT Standard Systems:			
PD500		500	800-1200
PD500W	W	500	800-1200
Extended Radius Systems:			
PD350EX		350	800-1500
PD350EXW	W	350	800-1500
For use with PORTA-BASE System			
PD500R		500	800-1000
PD500RW	W	500	800-1000
Man Ride PORTA-DAVIT System			
PD120MRW	W	120	800-1200

DISCLAIMER

All Reid sockets & extensions have been designed, developed and tested for safe use with Reid's equipment and form a key part of the integrity of the total system.

- All Sockets have a WLL of 500KG
- All sockets are supplied in Galvanised Mild Steel or Stainless Steel (316L grade, passivated)
- Sockets can be powder coated upon request .e.g. Yellow for trip hazard warning.

Should non standard third party sockets be used the CE requirement for Declaration of Conformity & Incorporation on the products is negated.



Flush Mount

Top Mount

Side Mount

Bridge Mount

Bespoke

Socket Extensions



LIGHTWEIGHT PORTABLE SAFE



Reid Lifting Limited
Unit 1 Severnlink
Newhouse Farm Industrial Estate
Chepstow
Monmouthshire NP16 6UN
enquiries@reidlifting.com
Tel: +44 (0)1291 620796
Fax: +44 (0)1291 626490



Reid Lifting France
16 Quater
Avenue Martyrs de la Resistance
56250
Elven, France
reidlifting@wanadoo.fr
Tel: +33 (0)297 53 32 99
Fax: +33 (0)297 53 04 86



BPF Distributors & Pumps Limited
Industrial Estate, Killough Road,
Downpatrick, Co. Down BT30 6LJ
NI
Tel: +44 (0)28 4461 5777
Fax: +44 (0)28 4461 4250
ROI
Tel: +353 (0)1 478 0665
Fax: +353 (0)1 478 0678
info@bpf-ltd.com & www.bpf-ltd.com



KAMAB Lyftsystem AB
Box 74, Rallarvägen 15
184 21 Åkersberga, Sweden
Tel: +46 (0)8540 69180
Fax: +46 (0)8540 60566
www.kamab.nu



Thern, Inc.
5712 Industrial Park Road
PO Box 347
Winona, MN 55987
USA
Phone: 507.454.2996
Toll Free: 800.843.7648
Fax: 507.454.5282
info@thern.com

REID Lifting – the best night's sleep in the lifting industry

- Systems are type tested at NAMAS accredited laboratories
- Every individual system is tested to 150% of WLL rating prior to shipment
- Full product design & development Technical Files are available for inspection
- Lifting Equipment Engineers Association (LEEA) full membership
- ISO9001 Quality Management Systems accreditation
- ISO14001 accreditation environment management systems and standards
- OHSAS18001 Occupational Health and Safety Management accreditation
- Certification of products by relevant recognised bodies from sockets to systems
- Safe assembly, use and maintenance manuals and training are available for all systems

WHAT'S NEXT

Further information and support can be found on our website www.reidlifting.com



CALL US

+44 (0)1291 620796



EMAIL US

enquiries@reidlifting.com



WEB

www.reidlifting.com