

Flammable Gas Detectors

Product Data

Document Ref: SL-034

MK8
PELLISTOR

IGD

International Gas Detectors

FLAMMABLE GAS DETECTORS

IGD have been designing and manufacturing Pellistor based catalytic flammable gas detectors for over 65 years. The IGD MK8 is our latest development. The MK8 combines reliability with tested performance. Allied with the low cost of ownership, our MK8 is the most advanced, poison resistant flammable gas detector on the market.



▶ EXTREME STABILITY

Minimal Zero drift over long periods

▶ RESPONDS TO ANY FLAMMABLE GAS

Pellistors respond to any flammable gas or vapour and can be calibrated for a specific target gas

▶ HIGH RELIABILITY

Proven design backed by third party approvals. ATEX/IECEx Zoned 1 and 2 flammable atmospheres and Zone 21, 22 dust environments.

▶ EXTREME RESISTANCE TO POISONING

A badly designed Pellistor (catalytic) gas detector can be susceptible to having its catalyst poisoned or inhibited from operation when exposed to lead or silicone compounds. Our MK8 has been specifically designed to deal with this problem exhibiting excellent performance in all conditions.

▶ LONG LIFE LOW COST OF OWNERSHIP

The MK8 has a long service life, typically 5 years. The sensor is plug replaceable allowing the stainless steel housing to be retained. This is part of IGD's green initiative to reduce environmental impact and cost to our clients.



INVESTORS
IN PEOPLE



FS646773

EMS696504



internationalgasdetectors.com

Triton House



+44 (0)161 483 1415

Crosby Street



sales@internationalgasdetectors.com

Stockport



/international-gas-detectors-ltd

SK2 6SH

Extreme Poison Resistance

Pellistors can be affected by ‘poisons’ and inhibitors. IGD’s best in class MK3 pellistor has lead the way for poison resistance since the 1980's significantly out performing all others. We didnt think we could make it better but we have. The new MK8 shows extreme resistance to poisoning agents. The graph below shows results from our standard poisoning test MK8 vs MK3 vs our nearest competitor. Industry standard tests only apply 10ppm poisoning agent for 40 minutes. IGD’s standard test requires 100ppm for 40 minutes to simulate real world conditions. IGD’s new MK8 exhibits extreme poison resistance.

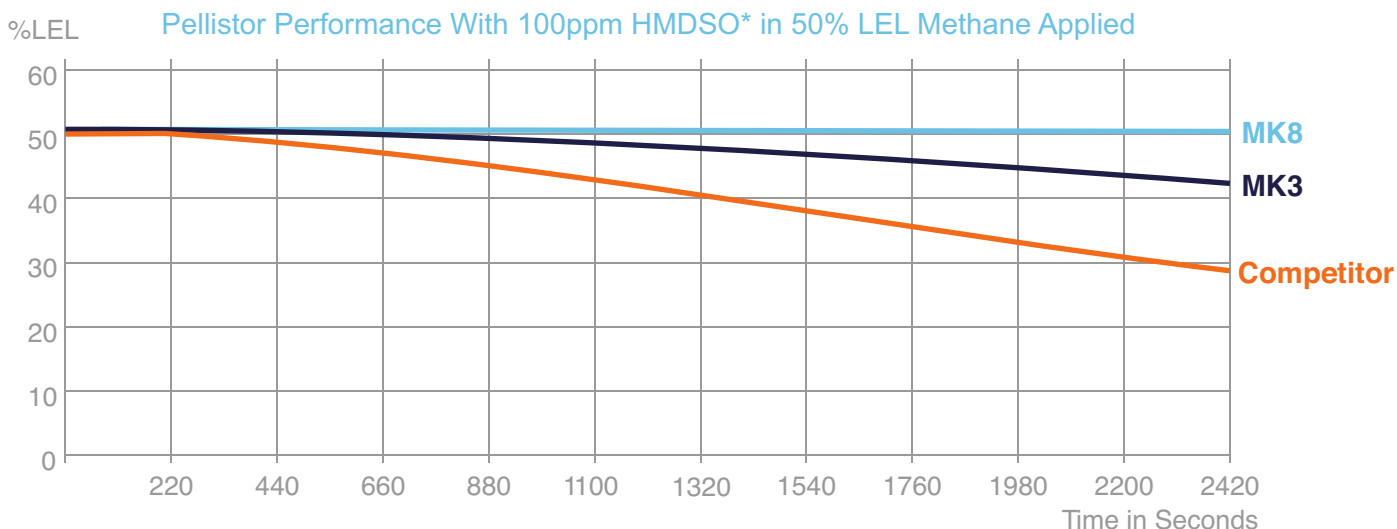

Extreme Sensor Performance from the MK8

- ▶ Extreme poison resistance exceeding industry standards IEC EN 50194 / IEC/EN 60079-29-1.
- ▶ Extreme stability less than 2% LEL drift per year.
- ▶ Resistant to shock and vibration meeting or exceeding the requirements of IEC/EN 60079-29-1.
- ▶ Only responds to flammable gases.
- ▶ Operates over a wide temperature range.
- ▶ Unaffected by humidity.
- ▶ Calibrations for a wide range of target gases (see following table indicating some common gases). If you dont see your gas listed, contact our team of gas detection experts: sales@internationalgasdetectors.com

Gas	LEL Europe (IEC80079-20-1)	Relative Response %	Gas	LEL Europe (IEC80079-20-1)	Relative Response %
Methane	4.4	100	Propane	1.7	54
Acetone	2.5	22	Toluene	1	24
Ethanol	3.1	27	Propylene	2	74
Ethyl acetate	2	22	Cyclo-hexane	1	44
Ethylene	2.3	56	Cyclo-pentane	1.4	63
Hydrogen	4	97	Iso-butane	1.3	46
Iso-propanol	2	19	Iso-octane	0.7	36
Methanol	6	46	n-octane	0.8	40
n-Butane	1.4	47	Styrene	1	14
n-Heptane	0.85	40	Xylene	1	26
n-Hexane	1	42	Carbon monoxide	10.9	42
n-Pentane	1.1	41	Ammonia	15	68

Table represents a small extract of typical gases
 * HMDSO - Hexamethyldisiloxane



JB3/903

II 2G Ex db IIC T6/T5 Gb
 II 2D Ex tb IIIC T85°C/ T100°C Db
 Ta = -20°C to +40°C/+55°C
 IECEx EXV 16.0002X
 ExVeritas 16 ATEX 0140X
 ExVeritas 21UKEX0913X
 IP66 M20 x 1.5 Entries 12-32V DC
 Compliant to IEC 60079-29-1

102 Series Detector

II 2G Ex db IIC T6 Gb
 II 2D Ex tb IIIC T85°C Db
 Ta = -20°C to +40°C
 II 2G Ex db IIC T5 Gb
 II 2D Ex tb IIIC T100°C Db
 Ta = -20°C to +55°C
 Rating 12-32VDC 2W
 IECEx EXV16.0003X
 ExVeritas 16ATEX0141X
 ExVeritas 21UKEX0914X

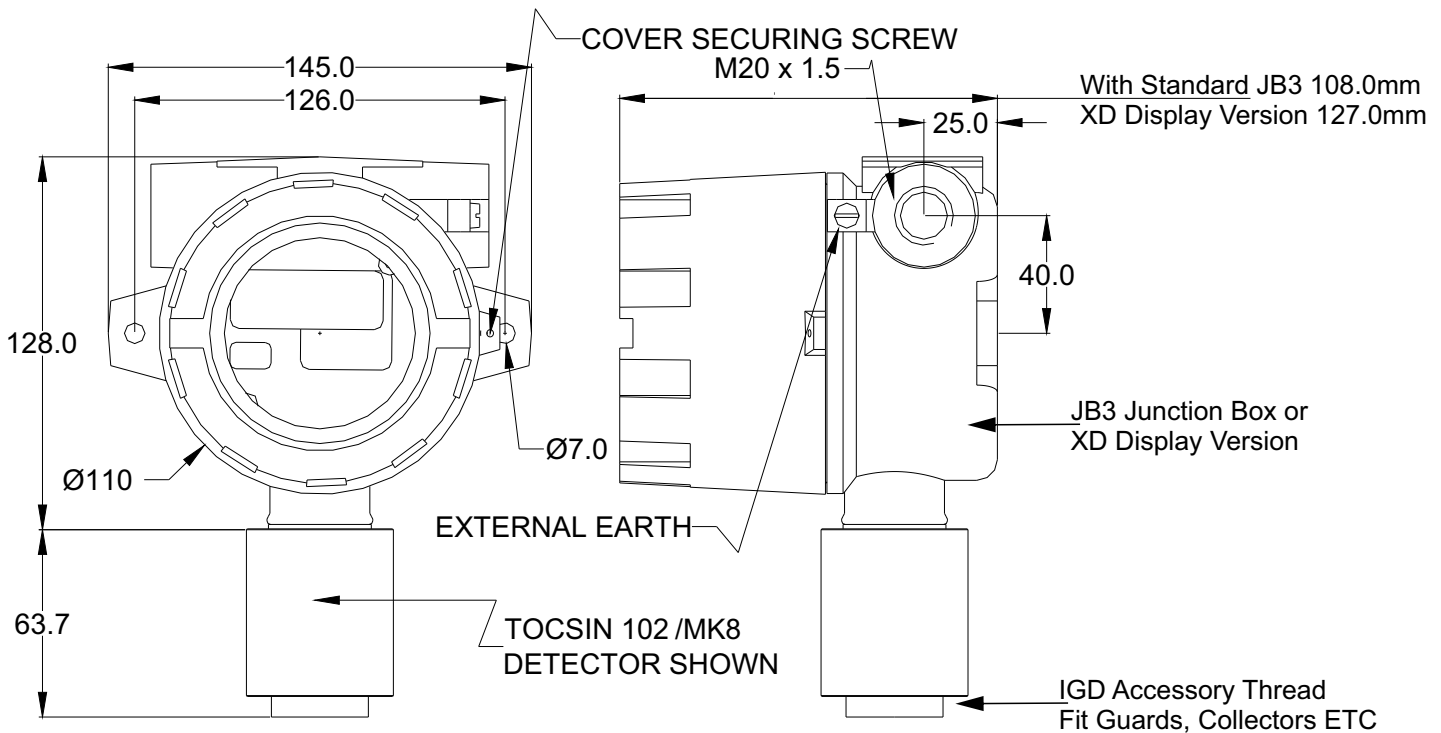

Power	12 to 32V DC without Relay Option Typically 4W	Storage Temperature	-20 Deg Celsius to +55 Deg C
Electrical Outputs	2 Wire Sentinel+™ Addressable I/O Digital Communication Linear over Detector Range.	Storage Humidity	20-90% RH Non-Condensing
JB Housing Material	Junction Box, Copper Free Aluminium Alloy Epoxy Coated Option for 316 Stainless Steel and Marine Paint Finishes	Shelf Life	5 Years
Sensor Housing Material	Sensor, Stainless Steel 316 S16	Sealing	IP66*
Explosion Protection	Junction Box, Ex d IIC T6 I I2 D G	Mounting	Wall Mount
Explosion Protection Sensor	Ex d IIC T6 I I2 D G	Weight	1.5Kg
Housing Dimensions (mm)	110 Diameter x 127 High Plus Detector Option	Measured Range	0-100% LEL (see gas list)
Cable Entry	2 x M20 x 1.5 Cable Entries 1 x M20 x 1.5 Detector Entry	T90 Time	<60 seconds
		T50 Time	<20 seconds
		Pressure	80 to 120kPa
		Humidity	0 to 90% RH non condensing
		Temperature T5	-20 to +55 Deg C
		Temperature T6	-20 to +40 Deg C
		Warm up Time	Set by controller, 15 minutes

* IP ratings do not imply that the equipment will detect gas during and after exposure to these conditions. Calibration and maintenance may be required more frequently and should be assessed based upon exposure.



International Gas Detectors

EC Declaration of Conformity

Declares that the product listed as:

TOC-750X
TOC 750-XD

Addressable Gas Detection Control Panel

Are in conformity with the provisions of the following European Directive(s) when installed, operated, serviced and maintained in accordance with the installation and operating instructions contained in the product documentation.

2004/108/EC **EMC Directive**
2014/34/EU **ATEX Directive** (note not applicable to 24V DC Powered Versions)

And that the standards and/or technical specifications referenced below have been applied or considered.

Issuers name and address:

Oliver IGD Limited of
Triton House
Crosby St,
Stockport,
SK2 6SH
United Kingdom

IEC 60079-0:2017 7th Ed	Explosive Atmospheres Equipment General Requirements
IEC 60079-29-1:2016 2nd Ed	Explosive Atmospheres. Gas Detectors. Performance Requirements of Defectors for Flammable Gases.
IEC 60079-1	Equipment protection by flameproof enclosures 'd'
EN 50270	Electromagnetic compatibility - Electrical Equipment for the Detection and Measurement of Combustible Gases, toxic Gases or Oxygen
IEC 60529	Degree of Protection to IP66
EN 60068-2-6	Vibration
EN 50271	Electrical apparatus for the detection and measurement of combustible gases, toxic gases or oxygen. Requirements and tests for apparatus using software and/or digital technologies
EN 60335:2012+A11:2014	Electrical Safety
IEC 61010-1:2010 +A1:2016	Safety requirements for electrical equipment for measurement, control, and laboratory use
EN 61010-1: 2010 +A1:2019	
Technical File Reference	T750-TF9

Oliver IGD Limited Operate an Independently assessed ATEX/IECEX QAN.

Quality Assurance Certificate Number
16PQAN0014

Quality Assurance Notification Number:
2585

Product Certificates

16ATEX0140X
16ATEX0141X
16ATEX0142X



Units 16-18 Abenbury Way,
Wrexham Industrial Estate,
Wrexham, LL13 9UZ
United Kingdom



FS646773 EMS696504

Oliver IGD Limited operate an independently assessed ISO9001:2015 Quality Management and ISO14001:2015 Environmental Management System
Certificate Numbers
FS0646773 & EMS696504

BSI Assurance UK LTD,
London, W4 4AL
United Kingdom



IMQ S.p.A con Socio Unico
Via Quintiliano 43
Italia 20138 Milano
www.imq.it



[Ex Gb] IIC

Report Ref AT19-0036585-01

Issued by: Oliver IGD Limited, Stockport, SK2 6SH , United Kingdom

Signature:

Declaration of Conformity in accordance with EN ISO/IEC 17050-1:2010

Name: Andrew J Collier M.I.O.D
Position: Managing Director

Date: 17 May 2021

Declaration Ref: MK8-DEC-1



FS646773 EMS696504

internationalgasdetectors.com
+44 (0)161 483 1415
sales@internationalgasdetectors.com
/international-gas-detectors-ltd

Triton House
Crosby Street
Stockport
SK2 6SH